

A photograph of a port terminal. In the foreground, a worker in an orange shirt and blue hard hat is working on a large, dark, cylindrical object, possibly a fender, which is being hoisted by a crane. The crane's arm is visible at the top of the frame. In the background, other workers and port infrastructure are visible, including a large crane with 'LBCT' written on it. The scene is set against a backdrop of a blue sea and a clear sky.

SPC Cone Fenders.

Characteristics

- ▶ Exceptionally good energy absorption to reaction force ratio (E/R)
- ▶ Outstanding energy absorption per fender weight
- ▶ High shear stability
- ▶ No loss of performance up to 10° contact angle
- ▶ Sophisticated and optimized fender geometry
- ▶ Optional overload stopper

Applications

- ▶ Container & Bulk Terminals
- ▶ Oil & Gas Terminals
- ▶ General Cargo Terminals
- ▶ Cruise Terminals
- ▶ Ferry & RoRo Terminals
- ▶ Navy

SPC FENDER DIMENSIONS

Fender Size	H [mm]	Ø D [mm]	Ø d [mm]	t [mm]	E [mm]	Ø PD [mm]	Ø Pd [mm]	Anchors/ Bolts	Weight [kg]
SPC 300	300	500	262	18	38	440	210	4 x M20	35
SPC 350	350	575	306	20	38	510	245	4 x M20	53
SPC 400	400	650	350	20	38	585	280	4 x M20	75
SPC 500	500	820	435	22	45	730	350	4 x M24	149
SPC 600	600	900	525	23	45	810	420	4 x M24	251
SPC 700	700	1,120	615	26	72	1,020	490	4 x M30	395
SPC 800	800	1,280	700	31	72	1,165	560	6 x M30	592
SPC 900	900	1,450	785	36	72	1,313	630	6 x M30	850
SPC 1000	1,000	1,600	875	38	82	1,460	700	6 x M36	1,128
SPC 1100	1,100	1,760	963	40	92	1,605	770	6 x M42	1,484
SPC 1150	1,150	1,850	1,010	41	92	1,550	805	6 x M42	1,714
SPC 1200	1,200	1,920	1,050	46	92	1,750	840	8 x M42	1,938
SPC 1300	1,300	2,080	1,140	50	105	1,900	910	8 x M48	2,413
SPC 1400	1,400	2,240	1,230	53	105	2,040	980	8 x M48	2,915
SPC 1600	1,600	2,560	1,400	64	105	2,330	1,120	8 x M48	4,357
SPC 1800	1,800	2,880	1,575	74	120	2,620	1,260	10 x M56	6,203
SPC 2000	2,000	3,090	1,750	80	120	2,920	1,400	10 x M56	8,074

Intermediate or larger sizes available upon request

SPC FENDER DRAWING

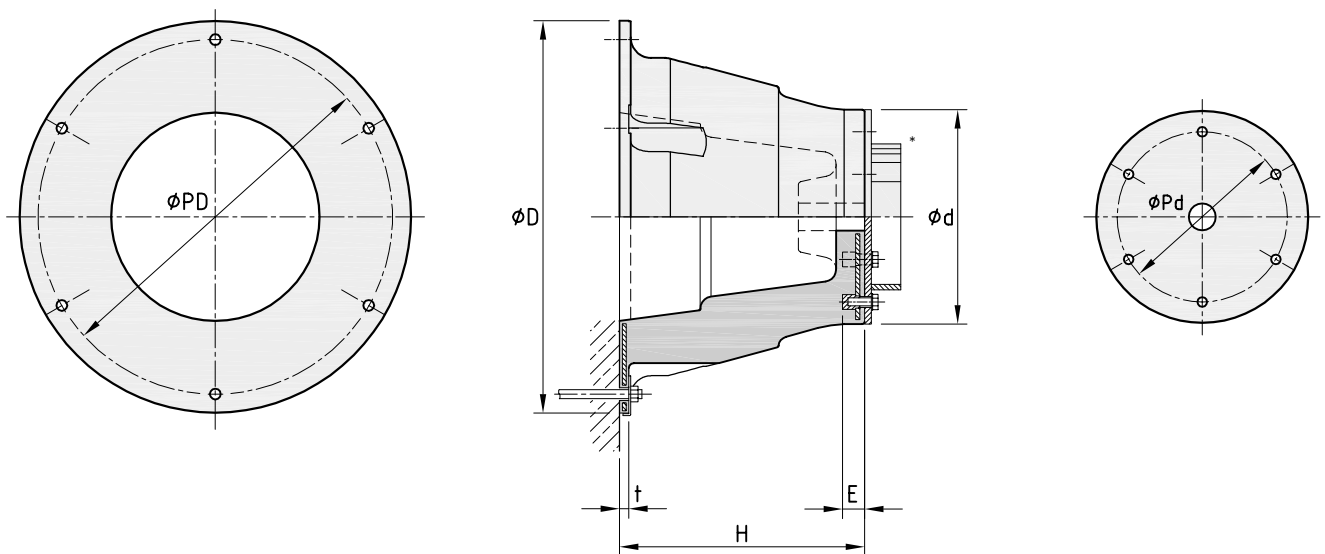

* Steel panel spool piece

PERFORMANCE TABLE SPC FENDERS (RPD = Rated Performance Data in acc. with PIANC)

Fender Size		E/R	Rubber Grades									
			G 0.9	G 1.0	G 1.1	G 1.2	G 1.3	G 1.4	G 1.5	G 1.6	G 1.7	G 1.8
SPC 300	E _A	0.16	9	9	10	10	10	11	11	12	12	12
	R _F		55	57	60	62	65	68	70	73	76	78
SPC 350	E _A	0.17	13	14	14	15	15	16	16	17	17	18
	R _F		76	78	91	93	96	98	100	102	104	107
SPC 400	E _A	0.21	21	21	22	23	24	25	26	27	28	29
	R _F		98	102	106	111	115	120	125	129	134	138
SPC 500	E _A	0.26	40	42	44	46	47	49	51	53	55	57
	R _F		153	159	166	173	180	188	195	202	209	217
SPC 600	E _A	0.31	69	72	75	79	82	85	88	92	95	98
	R _F		220	229	239	249	260	270	281	291	302	312
SPC 700	E _A	0.36	111	114	120	125	130	136	141	146	151	156
	R _F		300	312	325	340	354	368	382	397	411	425
SPC 800	E _A	0.42	165	170	179	187	194	202	210	218	226	233
	R _F		392	407	425	444	462	481	500	518	537	555
SPC 900	E _A	0.47	234	243	254	265	277	288	299	310	321	332
	R _F		496	515	538	562	585	609	632	656	680	703
SPC 1000	E _A	0.52	321	333	349	364	379	394	410	425	440	455
	R _F		612	636	665	694	723	752	781	810	839	868
SPC 1100	E _A	0.57	427	443	465	484	504	524	546	566	586	606
	R _F		741	767	805	840	875	910	945	980	1,015	1,050
SPC 1150	E _A	0.60	487	506	529	552	575	599	622	645	668	691
	R _F		810	841	879	918	956	995	1,033	1,072	1,110	1,149
SPC 1200	E _A	0.62	554	575	601	628	654	680	706	733	759	785
	R _F		882	916	958	1,000	1,042	1,083	1,125	1,167	1,209	1,251
SPC 1300	E _A	0.68	706	732	766	799	833	866	900	933	967	1,000
	R _F		1,030	1,070	1,118	1,167	1,216	1,265	1,314	1,363	1,412	1,461
SPC 1400	E _A	0.74	881	914	956	998	1,040	1,082	1,123	1,165	1,207	1,249
	R _F		1,201	1,247	1,304	1,361	1,418	1,475	1,532	1,589	1,646	1,703
SPC 1600	E _A	0.84	1,316	1,364	1,426	1,489	1,551	1,616	1,682	1,744	1,807	1,869
	R _F		1,567	1,628	1,702	1,780	1,855	1,929	2,004	2,078	2,152	2,227
SPC 1800	E _A	0.94	1,874	1,942	2,031	2,120	2,208	2,301	2,395	2,483	2,572	2,661
	R _F		1,984	2,061	2,156	2,255	2,350	2,445	2,539	2,633	2,729	2,823
SPC 2000	E _A	1.04	2,570	2,664	2,786	2,908	3,029	3,157	3,285	3,407	3,529	3,650
	R _F		2,450	2,544	2,661	2,784	2,901	3,018	3,135	3,252	3,369	3,485

Performance values for single units | Energy Absorption (E_A) in kNm, Reaction Force (R_F) in kN | Nominal rated deflection is 70%, max. deflection is 74% | Actual deflection at Rated Performance Data may vary | Properties, tolerances, and testing standards can be found on pages 123 ff.

GENERIC PERFORMANCE CURVE SPC FENDERS

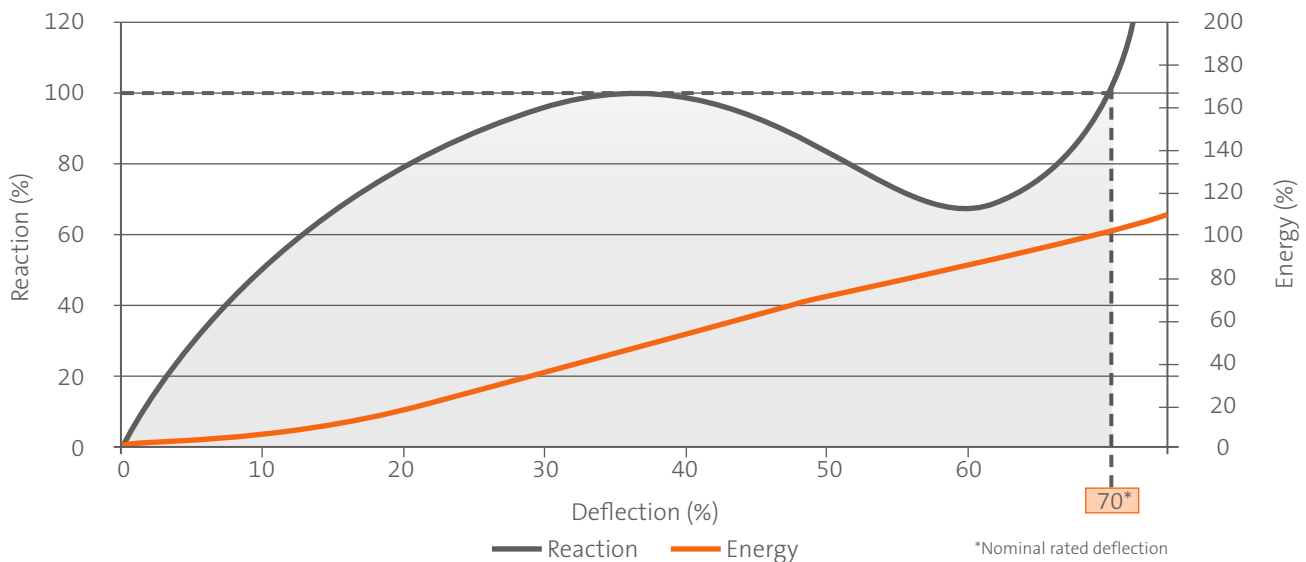

Rubber Grades													Fender Size
G 1.9	G 2.0	G 2.1	G 2.2	G 2.3	G 2.4	G 2.5	G 2.6	G 2.7	G 2.8	G 2.9	G 3.0	G 3.1	
13 81	13 83	14 86	14 89	14 91	15 94	15 96	16 99	16 102	16 104	17 107	17 110	18 112	SPC 300
18 109	19 111	19 114	19 117	20 120	20 123	21 126	21 129	22 132	22 135	23 138	23 141	28 155	SPC 350
30 143	31 148	32 152	33 157	34 162	35 166	36 171	37 176	38 180	39 185	40 190	41 194	42 199	SPC 400
59 224	61 231	63 238	65 246	66 253	68 260	70 268	72 275	74 282	76 289	78 297	80 304	82 311	SPC 500
102 323	105 333	108 344	111 354	115 365	118 375	121 385	125 396	128 406	131 417	135 427	138 438	141 448	SPC 600
162 439	167 454	172 468	177 482	183 496	188 511	193 525	198 539	203 553	209 568	214 582	219 596	224 610	SPC 700
241 574	249 593	257 611	265 630	272 648	280 667	288 686	296 704	304 723	311 741	319 760	327 779	335 797	SPC 800
343 727	354 750	365 774	376 797	388 821	399 844	410 868	421 891	432 915	443 939	454 962	465 986	476 1,009	SPC 900
471 897	486 926	501 955	516 984	531 1,013	547 1,043	562 1,072	577 1,101	592 1,130	608 1,159	623 1,188	638 1,217	653 1,246	SPC 1000
627 1,085	647 1,120	667 1,156	687 1,191	707 1,226	728 1,262	748 1,297	768 1,332	788 1,367	809 1,402	829 1,437	849 1,473	869 1,508	SPC 1100
714 1,187	737 1,225	760 1,264	784 1,302	807 1,341	830 1,379	853 1,418	876 1,456	899 1,495	922 1,533	945 1,571	969 1,610	992 1,648	SPC 1150
812 1,293	838 1,335	864 1,377	890 1,418	917 1,460	943 1,502	969 1,544	996 1,586	1,022 1,628	1,048 1,670	1,074 1,712	1,101 1,753	1,127 1,795	SPC 1200
1,034 1,510	1,067 1,559	1,101 1,608	1,134 1,656	1,168 1,705	1,201 1,754	1,234 1,803	1,268 1,852	1,301 1,901	1,335 1,950	1,368 1,999	1,402 2,048	1,435 2,097	SPC 1300
1,291 1,760	1,332 1,817	1,374 1,874	1,416 1,931	1,458 1,988	1,499 2,045	1,541 2,102	1,583 2,159	1,625 2,216	1,667 2,273	1,708 2,330	1,750 2,387	1,792 2,444	SPC 1400
1,931 2,301	1,994 2,376	2,056 2,495	2,118 2,524	2,181 2,599	2,243 2,673	2,305 2,747	2,368 2,882	2,430 2,896	2,442 2,971	2,555 3,045	2,617 3,119	2,673 3,190	SPC 1600
2,750 2,918	2,838 3,013	2,927 3,108	3,016 3,202	3,105 3,297	3,194 3,392	3,282 3,486	3,371 3,581	3,460 3,676	3,549 3,771	3,637 3,865	3,726 3,960	3,806 4,050	SPC 1800
3,772 3,602	3,894 3,719	4,016 3,836	4,137 3,953	4,259 4,070	4,381 4,187	4,503 4,304	4,624 4,421	4,746 4,538	4,868 4,655	4,990 4,772	5,111 4,889	5,221 5,000	SPC 2000



Ferry Terminal | Zadar | Croatia



Eurotank Jetty | Amsterdam | The Netherlands

CORRECTION FACTORS

FENDER PERFORMANCE AT INTERMEDIATE DEFLECTION

Deflection of original fender height [%]	0	5	10	15	20	25	30	35	40	45	50	55	60	65	70	72	73	74
Energy Absorption of original value [%]	0	1	5	10	17	25	34	44	53	62	71	78	85	92	100	104	107	110
Reaction Force of original value [%]	0	27	48	65	79	90	97	100	99	93	84	73	68	76	100	132	148	165

TEMPERATURE FACTOR

Temperature [°C]	-60	-50	-40	-30	-20	-10	0	10	23	30	40	50	60
Correction Factor	Contact your local SFT office for special compound consultation			1.559	1.375	1.182	1.083	1.034	1.000	0.976	0.945	0.918	0.917

VELOCITY FACTOR

Compression Time [s]	1	2	3	4	5	6	7	8	≥ 10
Correction Factor	1.050	1.020	1.012	1.005	1.000	1.000	1.000	1.000	1.000

ANGLE FACTOR

Compression Angle [°]	0	3	6	9	10	12	15	20
Energy Absorption of original value [%]	100	100	100	100	100	96	92	80
Reaction Force of original value [%]	100	100	100	100	100	100	100	100

INSTALLATION CLEARANCES

Fender Size	H [mm]	i [mm]	j [mm]	k [mm]	ED [mm]
SPC 300	300	225	540	45	≥ 300
SPC 350	350	263	630	53	≥ 350
SPC 400	400	300	720	60	≥ 400
SPC 500	500	375	900	75	≥ 500
SPC 600	600	450	1,080	90	≥ 600
SPC 700	700	525	1,260	105	≥ 700
SPC 800	800	600	1,440	120	≥ 800
SPC 900	900	675	1,620	135	≥ 900
SPC 1000	1,000	750	1,800	150	≥ 1,000
SPC 1100	1,100	825	1,900	165	≥ 1,100
SPC 1150	1,150	863	2,070	175	≥ 1,150
SPC 1200	1,200	900	2,160	180	≥ 1,200
SPC 1300	1,300	975	2,340	195	≥ 1,300
SPC 1400	1,400	1,050	2,520	210	≥ 1,400
SPC 1600	1,600	1,200	2,880	240	≥ 1,600
SPC 1800	1,800	1,350	3,240	270	≥ 1,800
SPC 2000	2,000	1,500	3,600	300	≥ 2,000

The fender system design should allow for:

- ▶ increased diameter of SPC Fenders during compression [j]
- ▶ sufficient clearance of front panel [i]
- ▶ minimum edge distance for anchoring and to other protrusions [ED]
- ▶ angular compression
- ▶ spool piece [k]

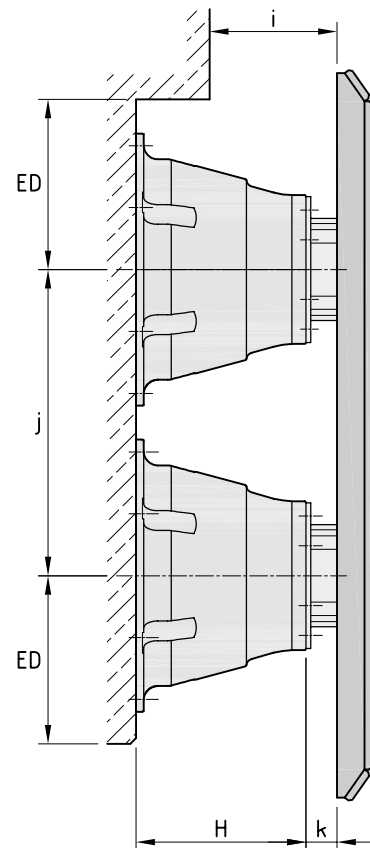

WEIGHT SUPPORT CAPACITY

Due to its geometry, the SPC Fender can support a front panel with at least the same weight as the fender body itself. For panels with a higher weight, SFT recommends the use of weight support chains.*

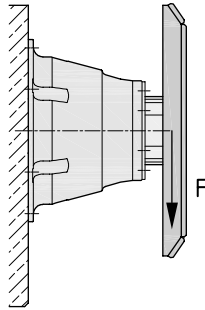

TENSION

Tension chains are recommended, especially when tensile loads might exceed the rated reaction force of the rubber fender.*

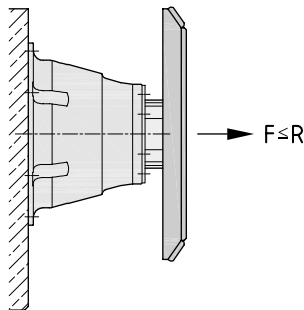

SHEAR

SPC Fenders are very stable against horizontal and vertical shear forces. However, depending on the application and layout of the system, shear chains might become necessary.*

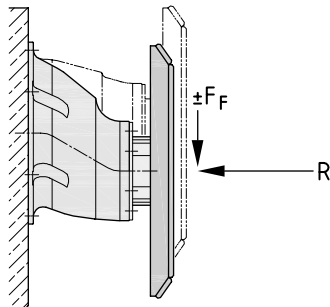

Mauritius Container Terminal | Port Louis | Mauritius



Oil Terminal | Pepel Island | Sierra Leone



Container Terminal | Aqaba | Jordan

* For detailed advice, please contact your local SFT office
SFT generally recommends the use of properly designed suspension chain systems to support the fender's performance and reduce the risk of damages