

RGX Series Heavy Duty Air Heaters

The Ruffneck™ RGX unit heater was designed by Thermon Heating Systems Inc. specifically for heavy duty use in industrial environments. This heater will reduce the downtime and maintenance costs usually experienced with heaters of standard design.

Applications

- Mine shafts
- Pulp and paper mills
- Hoist houses
- Welding shops
- Maintenance shops
- Sewage treatment plants
- Chemical plants
- Repair shops
- Wash down areas
- Weigh scale pits
- Elevator shafts
- High humidity areas
- Crane cabs

Features

- cCSA_{US} approved for horizontal and vertical air flow
- Automatic reset high limit
- 15, 20, 25, 30, 40, 50 kW units (optional 10 kW unit)
- 40 and 50 kW units incorporate split loads (50%) for remotely controlled energy management systems
- Factory installed transformers, contactors, and thermostats where specified
- Individually adjustable air flow louvres
- Factory balanced aluminum fan blade
- Fan delay in **"ON"** and **"OFF"** cycles
- Full sized control panel with hinged removable door, constructed to NEMA 12 standards
- **"FAN ONLY"** terminals for connection to remote switch
- 14-gauge steel cabinet
- Epoxy painted (ASA 61 Grey) for superior resistance to corrosion
- 1/3 HP motor with sealed ball bearings and totally enclosed construction
- Ceiling mounting bracket supplied
- Motor mounted outside of the element bundle thereby eliminating premature failure due to overheating and providing easy access for motor maintenance
- Elements are robust KX finned tubular sheathed type with epoxy sealed terminals to eliminate contamination from moisture and airborne impurities



In Canada these units are marketed under the Caloritech™ brand name.

Optional Factory Installed Features

- Built-in thermostat 41°F to 100°F (5°C to 38°C)
- Disconnect switch with door interlock
- HRC main load fuses
- Fused control circuit
- Manual reset high limit
- **"FAN ONLY"** switch
- Low voltage relay for remote 24 V thermostat
- Epoxy painted fan blade and motor
- Special wattages and voltages
- Special control voltages (240 V is standard)
- Available in special finishes
- Split load feature 15, 20, 25, 30 kW units
- Alloy elements with brazed alloy fins
- Nickel plated elements
- Stainless-steel cabinet
- EEMAC 4 construction

Accessories for Field Installation

- FAT 8A field installed built-in thermostat kit 41°F to 100°F (5°C to 38°C)
- RWB210 wall mount bracket (2 to 10 kW)
- RWB1540 wall mount bracket (15 to 40 kW)
- Air diffuser (vertical air flow)
- **"FAN ONLY"** switch and cover plate
- Remote thermostats available

Mounting Configurations

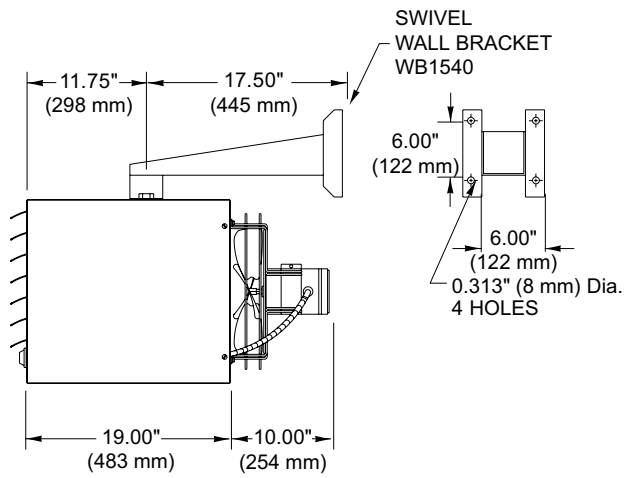

Figure 12 – Horizontal Air Flow Wall Mount

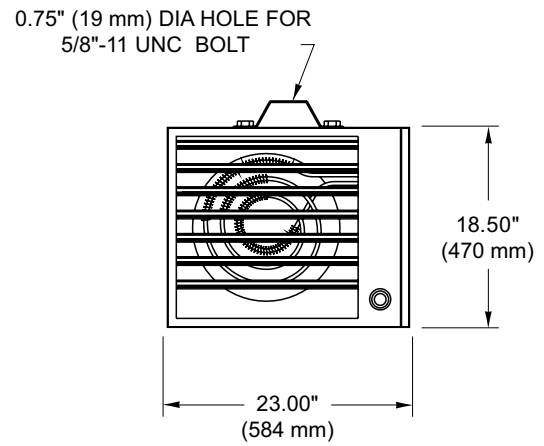

Figure 13 – Horizontal Air Flow Ceiling Mount

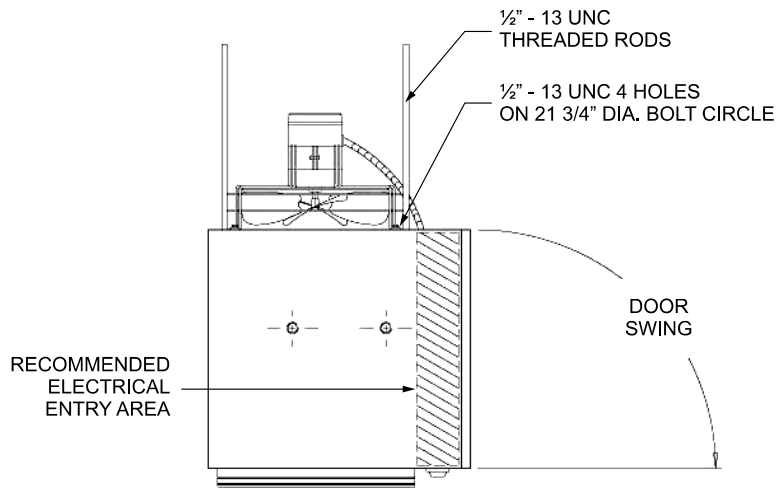

Figure 14 – Vertical Air Flow

To Order Specify

- Catalog number
- Voltage
- Phase
- kW
- Optional features
- Accessories

Table 27 – Performance Data for RGX Heavy Duty Air Heaters

kW (Btu/hr)	Volts	Phase	CFM	TEMP. RISE C° (F°)	Catalog Number			Net Weight
					Without Contactor	With Contactor	With T'stat & Contactor	
15 (51180)	208	3	1800	14 (25)	RGX152	RGX152C	RGX152CT	105 lbs 47.6 kg
	240		1800		RGX153	RGX153C	RGX153CT	
	480		1800		RGX157	RGX157C	RGX157CT	
	600		1800		RGX158	RGX158C	RGX158CT	
20 (68240)	208		1800	19 (34)	RGX202*	RGX202C*	RGX202CT*	105 lbs 47.6 kg
	240		1800		RGX203	RGX203C	RGX203CT	
	480		1800		RGX207	RGX207C	RGX207CT	
	600		1800		RGX208	RGX208C	RGX208CT	
25 (85300)	208		1800	24 (41)	RGX252*	RGX252C*	RGX252CT*	105 lbs 47.6 kg
	240		1800		RGX253*	RGX253C*	RGX253CT*	
	480		1800		RGX257	RGX257C	RGX257CT	
	600		1800		RGX258	RGX258C	RGX258CT	
30 (102360)	480	2100	24 (41)	RGX307	RGX307C	RGX307CT	105 lbs 47.6 kg	
	600	2100		RGX308	RGX308C	RGX308CT		
40 (136500)	480	2100	32 (58)	RGX407	RGX407C	RGX407CT	125 lbs 56.7 kg	
	600	2100		RGX408	RGX408C	RGX408CT		
50 (170600)	480	2100	40 (72)	RGX507	RGX507C	RGX507CT	125 lbs 56.7 kg	
	600	2100		RGX508	RGX508C	RGX508CT		

*These units exceed 48 amps, and may require special split load feature.

Note:

1. Motor voltage and phase is same as heater supply.
2. Standard control voltage is 240 V. A control transformer is included where required. Other control voltages are available. (Check with factory.)
3. 15, 20, 25, 30 kW units are pre-wired as one circuit. The split load feature (50%) is available as an option.
4. 40 and 50 kW units are pre-wired for split load (50%) control by customer unless specified otherwise.
5. All motors are 1/3 HP, totally enclosed ball bearing type, permanently lubricated, thermally protected.

Model Coding

RGX	20	3	C	T	L	-	D
Model Series	Kilowatts	Voltage	Contactor (Optional)	Thermostat (Optional)	Energy Management Controller (Optional)		Other Options
	15 - 15 kW	2 - 208					B - Epoxy painted fan blade and motor
	20 - 20 kW	3 - 240					D - Disconnect switch
	25 - 25 kW	7 - 480					F - Fan only switch
	30 - 30 kW	8 - 600					H - HRC main load fuses
	40 - 40 kW						K - Fused control circuit
	50 - 50 kW						M - Manual reset high limit
							N - Low voltage relay (24V)
							V - 120V control voltage (240V is standard)

RGX Series Specification Sheet

Scope

Heavy duty electric unit heaters, Ruffneck™ model RGX, as manufactured by Thermon Heating Systems, Inc. complete with ratings and features as specified below.

Ratings

- The heater(s) shall be of the heavy duty, forced air type, catalog number _____, rated _____ V, _____ phase, _____ Hz, _____ kW.
- The heater(s) shall be CCSAUS certified to CSA Standard C22.2 No. 46-M1988 Electric Air Heaters, and UL Standard 1025 Electric Air Heaters.

Standard Features

- Heavy duty unit heaters shall be approved for horizontal and vertical airflow.
- Heaters shall use Caloritech™ type KX finned tubular elements to transfer the heat. Elements shall have epoxy sealed terminals to eliminate the possibility of contamination from moisture and airborne impurities.
- Heaters rated 40 kW and 50 kW shall be provided (as standard) with 50% split loads for remotely controlled energy management systems. Split load feature shall be provided if specified on 15 kW to 30 kW units.
- Heater cabinets shall be 14-gauge steel, painted with ASA 61 grey epoxy for superior corrosion protection. The cabinet shall also incorporate a full sized control panel with hinged removable door, constructed to NEMA 12 standards.
- The heater shall have seven (7) individually adjustable, extruded aluminum louvers to direct the outlet airflow.
- Motors shall be of the totally enclosed type with permanently lubricated ball bearings and built-in thermal overload, rated 1/3 HP, 1725 RPM with the voltage rating the same as the heater. The motor shall be mounted outside of the element bundle to eliminate premature failure due to overheating and to provide easy access for maintenance.
- A factory balanced aluminum fan blade shall provide the airflow through the heater.
- The standard control voltage shall be 240 V. A built in transformer shall be supplied when required.
- Heavy duty unit heaters shall incorporate a fan delay in the "ON" and "OFF" cycles. "FAN-ONLY" terminals for connection to a remote switch shall also be supplied as standard.
- The heater shall be supplied with built-in overheat protection of the auto-reset, bimetal type.
- The heater shall be equipped with ceiling mount brackets as standard.
- Approximate heater dimensions shall be 18½" (470 mm) high x 23" (584 mm) wide x 30" (762 mm) long.
- Shipping weight shall be 105 lbs (48 kg) for 15 kW to 30 kW and 125 lbs (57 kg) for 40 kW & 50 kW units.

Optional Factory Installed Features

The following factory installed optional features (indicate with a check) shall be included:

- Built-in bulb and capillary thermostat, 41°F to 100°F (5°C to 38°C)
- Disconnect switch with door interlock
- HRC main load fuses
- Manual reset high limit
- "FAN-ONLY" switch
- Low voltage relay for remote 24 V thermostat
- Epoxy painted fan blade and motor
- Split load feature, 15 kW to 30 kW units
- Nickel plated elements
- Stainless-steel cabinet

Accessories for Field Installation

The following accessories (indicate with a check) shall be included with the unit for field installation:

- FAT 8A field installed built-in thermostat kit 41°F to 100°F (5°C to 38°C)
- Wall mount bracket: model RWB1540
- Air diffuser for vertical air flow